

CITIZEN QUARTZ Analog Alti-Meter

Model No. AY6***
Caliber No. 7240

• INSTRUCTION MANUAL

CTZ-B6771

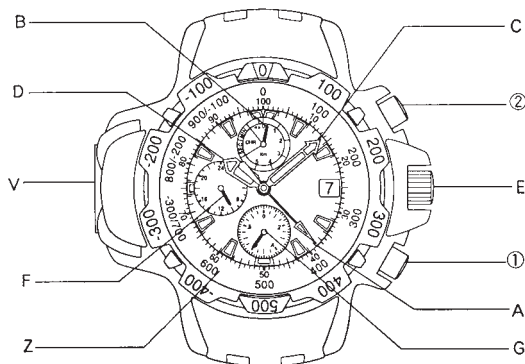

Thank you very much for purchasing a CITIZEN QUARTZ WATCH. To ensure correct use, please read these instructions carefully. Please ensure that the Citizen international guarantee card is supplied with watch on purchase, that you may claim the guarantee service (subject to the terms of guarantee).

Precautions for use

This watch is not a measuring instrument authorised by official authorities. Do not use the altimetry function to judge situation involving danger. The following precautions should be adequately understood before using the altimeter. Please remember that the altimetry function should be used only as general reference.

1. Do not use the Altimetry Function When...

The altimetry should not be used in the following situations:

- When judging your actions or situation involving danger in an environment where the temperature changes drastically.
- In an environment where pressure is subject to change, such as in an airplane or building (correct measurement cannot be obtained).
- When the altitude changes greatly within a short time.
- In case of special handling other than normal use, not described in this manual.

2. Altimetry Function

The altitude displayed by this watch is relative to altitude based on the sensed air pressure and "The international standard atmospheric pressure and altitude". Therefore, display of measured altitude will change if air pressure changes, even if measurement is made in the same place. the time

display from measurement to display of altitude is approximately 5 seconds (in continuously altimetry mode). Therefore, this altimetry function may not be used in sports as skydiving, etc., where altitude changes greatly within a short time. After 30 minutes, Continuous Altimetry Mode will automatically change to Altimetry Mode in which every measurement is made every hour. To resume Continuous Altimetry Mode, operate the watch as explained in the instruction manual. In order to efficiently use the altimetry function of this watch, the altitude must always be corrected for your location, clearly indicated with the altitude.

3. Pressure Sensor

Do not disassemble the pressure sensor used in this watch or poke it with a thin rod. Take care that no dust enters the pressure sensor.

4. Battery

Battery life will maintain accuracy for about 2 years under normal conditions after installing a new battery. However, the battery life will change depending on the frequency that the altimetry, chronograph are used. Thus, early replacement of the battery is recommended.

A. Basic Functions of the Altimeter

This watch is designed to calculate altitude from changes in air pressure by using the relationship between air pressure and altitude, based on the conditions for standard correct atmosphere* specified by the International Civil Aviation Organisation (ICAO). To obtain correct altitude on the watch, altitude must be aligned with an accurate point (triangulation station or benchmark). Such operation is called "Compensating the altitude" (see page 12)

* Standard atmosphere: ICAO Standard Atmosphere adopted by the ICAO in 1964, whereby 1013.25 hPa at 15°C is specified as elevation 0. However, air pressure continuously changes at any given place. This watch's operating is based on ISA standards. The following chart provides an outline of ISA standard configurations.

(from International Standard Atmospheric)

Altitude (m)	Atmospheric Pressure (hPa)	Temp (°C)	Temp diff. every 1,00
5,000	540.2	-17.5	Approx. 6.5°C
4,000	616.4	-11.0	
3,000	701.1	-4.5	
2,000	795.0	2.0	
1,000	898.7	8.5	
0	1,013.25	15.0	

B. Operating Instructions

Name	Time (Altimeter) Mode	Chronograph Mode	
A: Function hand	Altitude hand I.... Unit: 10 m	Indicates measurements of less than 1 minute.	Indicates measurements over than 1 minute.
		Chronograph second hand	Chronograph minute hand
B: Mode hand	Altitude hand II.... Unit: 1,000 m	Indicates chronograph measurements less than 1 minute.	Indicates chronograph measurements over than 1 minute.
C: Minute hand	Always displays minutes.		
D: Hour hand	Always displays hours.		
E: Crown	Used to set the time and date		
F: 24-hour-hand	Always displays 24-hour time synchronize with the hour hand.		
G: Second hand	Displays seconds	Chronograph 1/20 seconds	Chronograph second hand
①: Button ①	Switching modes among Time and, Chronograph, Altitude compensation		
②: Button ②	Chronograph start/stop/reset, continuous altimetry Altitude compensation		

- V: Pressure (altimetry) sensor:** Detects the atmospheric pressure and displays as altimetry via an IC.
- Z: Register-ring:** Setting the register-ring allows you to determine the difference in altitude. If the indicated altitude value changes at the same place, this indicates changes in the air pressure. If the altitude hand shifts to indicate a lower altitude the air pressure has increased.

C. Setting the Time and Date

[Time Mode]

- The time mode displays both 12-hour and 24-hour time.
- The hour, minute and 24-hour hands indicate the time even when the watch is in Chronograph Mode.

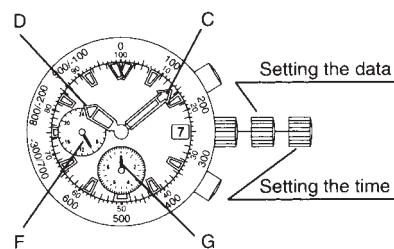

[Setting the Time and Date]

1. Setting the time
If your watch is a type with a screw-lock crown, unscrew the crown.

- Pull the crown out two steps. The second hand will spin rapidly and stop at 0.
- Set the hours and minutes to the current time by turning the crown. Check the 24-hour hand to confirm whether the hands are set appropriately to AM or PM.
- Push the crown back to its original position. The watch will then resume with the correct time.

2. Setting the date

- Pull the crown out one step.
- Set the desired date by turning the crown.
- Push the crown back to its original position.

Note: If setting the date between hours of 9.00 PM and 1:00 AM may result in the date not changing by the next day.

* If your watch is of a type with a screw-lock crown, tighten the crown after setting the time and/or date.

D. Altimetry

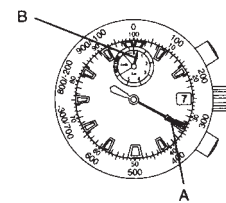

A: Altitude hand [I]
B: Altitude hand [II]

1. Altimetry

- The altimeter automatically measures altitude every hour in Time Mode.
- The altimeter measures and displays from -300m to 5,000m in 10m gradation.
- Altitude hand [I] (A) is synchronized with [II] (B) to display the current altitude.

Altitude hand [I] (A): Displays the altitude in 10m gradation.

Altitude hand [II] (B): Displays the altitude in 1,000m gradation.

Note: The altimeter displays “-300m” for an altitude less than -300m, and “5,000m” for more than 5,000m.

2. Reading the altimetry displays

(1) Altitude from 0 to 1,000 m

* The figure below shows an altitude of 190 m.

(2) Altitude from 1,000 to 2,000 m

* The figure below shows an altitude of 1,350 m.

(3) Altitude from -300 to 0 m

* The figure below shows an altitude of -100 m.

Altitude hand [II] (B) points to a position equivalent to 190 m.



① Altitude hand [I] (A) indicates 190 m.

Altitude hand [II] (B) points to a position equivalent to 1,350 m.



② Altitude hand [I] (A) indicates 350 m.

Altitude hand [II] (B) points to a position equivalent to -0.1.

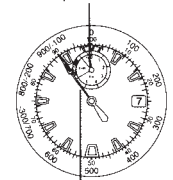

③ Altitude hand [I] (A) indicates -100 m.

3. Continuous altimetry

The watch shows continuous changes in altitude once every 5 seconds for 30 minutes after the starting measurement for altitudes.

- Measuring the altitudes.

Press button ② once in Time Mode. The second hand changes to operate on an extended 2-second increment basis. This indicates that the watch is now in Continuous Altimetry Mode.

Pressing button ② once returns the watch to altimeter mode. Also, the watch will automatically return to Altimeter Mode 30 minutes after being set to Continuous Altimetry Mode even if no button is pressed.

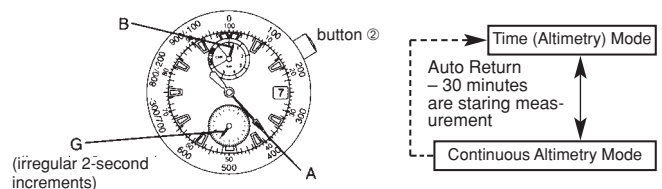

E. Altitude Compensation

The altitude displayed by this watch is relative altitude based on standard atmosphere. To obtain the correct altitude during mountain climbing, the altitude displayed by this watch must be aligned with an accurate altitude at a geographical point of reference (triangular station, first-order benchmark, an altitude on an accurate map, etc.). Such an operation is called "altitude correction". If air pressure changes 1 hPa, the altitude difference will be approximately 10m. Therefore, altitude compensation must be made several times a day if the weather changes drastically during mountain climbing.

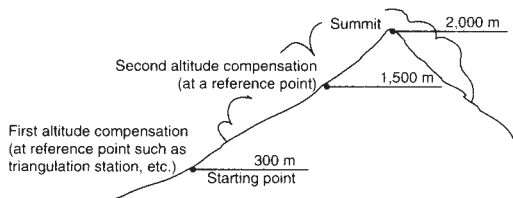

[Compensating the altitude]

The current altitude can be corrected within a range of $\pm 300\text{m}$.

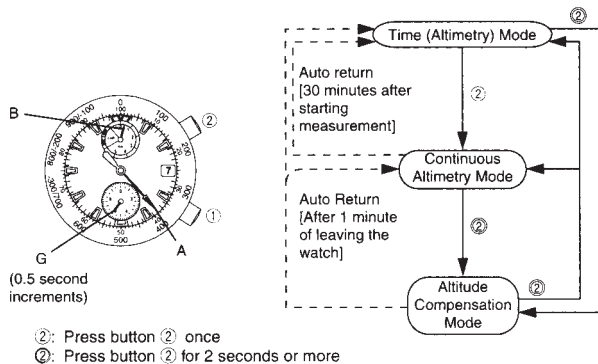

Compensation

- Press button ② for more than 2 seconds in Time Mode (or Continuous Altimetry Mode). The second hand (G) changes to indicate 0.5 second increments. This indicates that the watch is now in Altitude Compensation Mode.
- Press button ① or ② to compensate the altitude.
 - Button ①: Altitude Hand [I] (A) decrement up by 10m in each time the button is pressed.
 - Button ②: Altitude Hand [I] (A) increment by 10m in each time the button is pressed.
- After compensation is completed, return to Time Mode (or Continuous Altimetry Mode). Pressing button ② for 2 seconds or more, returns the watch to Time Mode (or Continuous Altimetry Mode).

Note: If the watch is left in the Altitude Compensation Mode for more than 1 minute it will automatically return to Time Mode or Continuous Altimetry Mode. (Auto Return)

F. Chronograph

1. Switching to Chronograph mode

Press button ① once in Time Mode. The function hand (A) and the second hand (G) will move forward to the 0 position. The mode hand (B) will advance to SEC (seconds). The watch is now in Chronograph Mode (reset).

* If the watch is left in Reset Chronograph Mode for 3 minutes it will automatically return to Time Mode.

2. Chronograph measurement

A maximum of 99 minutes and 59 seconds may be measured by the chronograph. After that, measurement stops automatically and the chronograph returns to the reset position.

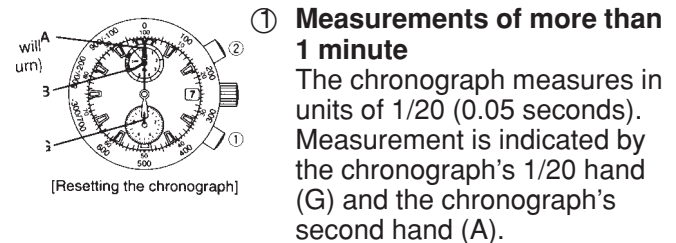

The mode hand (B) indicates the SEC (seconds) zone.

② Measurements of over 1 minute

The chronograph measures in one second increments. Measurement is indicated by the chronograph's second hand (G) and the chronograph's minute hand (A). The mode hand (B) indicates the MIN (minutes) zone.

3. Reading the chronograph's scales

- Measurements of less than 1 minute:
 Value are indicated by the chronograph's second hand (A) and 1/20 hand (G). To read seconds, use the outer scales. In Fig. A as follows, the chronograph displays 33.45 seconds. Once 60 seconds is reached, the second hand (A) will change to the minute hand and indicate 1 minute.

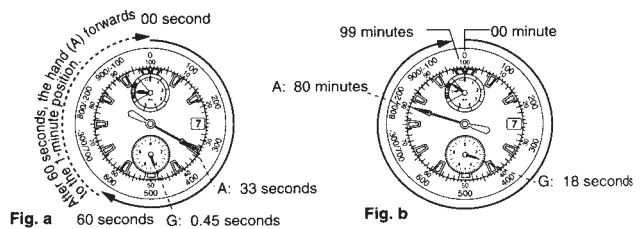

- Measurements of more than 1 minute:
 Value are indicated by the chronograph's minute hand (A) and second (G). To read minutes, use the outer scales. In Fig. B as follows, the chronograph indicates 80 minutes and 18 seconds). Once 100 minutes is reached, measurement automatically stops and the chronograph returns to the reset position.

4. Operating the chronograph mode

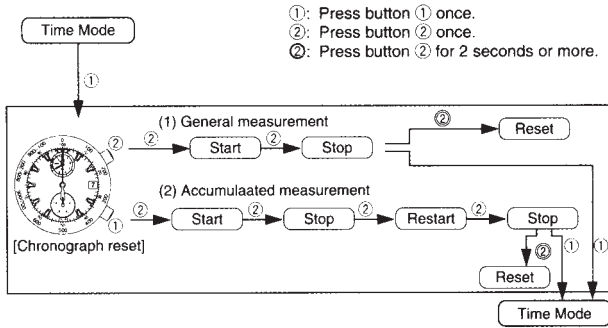

Note: The chronograph will be reset if the crown is pulled out two steps during chronograph measurement.

G. Battery-Low Warning Function

Accurate altimetry measurements cannot be made when the battery is low. To prevent inaccurate measurement, the altimeter stops measurement and the second hand (G) moves in 2-second increments to notify of battery low. Altitude hands [I] and [II] will stop at the altitude position where measurement has been stopped.

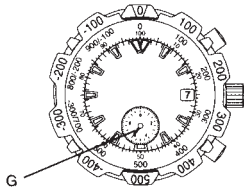

H. Adjusting Hands To "0" Position

Use the following steps to adjust the hands to the "0" position. After battery replacement or when resetting the chronograph, or if the seconds hand does not return to the "0" position when the crown is pulled out two steps.

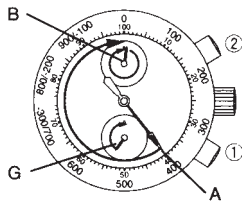

1. Pull the crown out two steps.
2. Depress button ① and ② simultaneously for 2 seconds or more.
The function hand (A) will move slightly
3. Press button ② and respectively align the function hand (A) and the mode hand (B) to the zero position.

(The function hand (A) is synchronized with the mode hand (B)).

*Depressing the button will advance the function/mode hands.

4. Press button ① to align the second hand to the zero position.

*Depressing the button will advance the second hand.

5. Push the crown back to its original position.

Function hand (A) will change to Altitude hand (I).

Note: Make sure to perform zero positioning after replacing the battery. Otherwise, correct altimetry and chronograph measurement may not be performed.

I. Care for Long Term Use

[Pressure sensor]



Pressure sensor

- The sensor cover is for protecting the pressure sensor. Do not remove it.
- The sensor area of this watch requires proper ventilation. If the sensor area is sealed with foreign articles, the altimetry function will not operate correctly.
If the sensor area is clogged with dust, sand or other dirt, take it to our Service Centre.

- If water has entered and frozen in the sensor area, the sensor may not operate correctly. If water has entered the watch, dry it thoroughly before using it. The watch can suffer substantial damage from contact with salt water.
If such contact occurs, it should be thoroughly rinsed with fresh water immediately.

J. Register Ring

The register ring of this watch has numbers from -400 to 500m whereby roughly the altitude difference between the current location and destination can be seen easily.

Register ring can be turned backward and forward

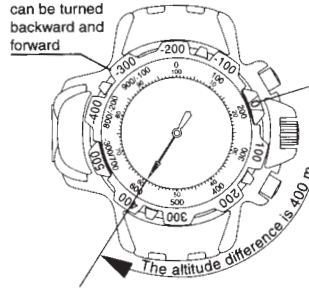

A: Altitude Hand [I]:
The altitude difference is 400m.





[Example 1]

When altitude hand [I] indicates an altitude of 200m at the current location, align "0" on the register ring to altitude hand [I].

If the figure on the register ring corresponding to altitude hand [I] is at "400m" when you arrive at the destination (or at any point on the way), the altitude difference is 400m. However, pay attention to the position of altitude hand [II].

K. Precautions

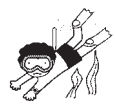
Water resistance

Classification	Specification	Indication		Water-related use				
		Dial	Case back					
Reinforced water resistance for daily life	5 bar water resistant watch	WATER RESISTANT WR***/**bar	WATER RESIST (ANT)	OK	OK	NO	NO	NO
	10 / 20 bar water resistant watch			OK	OK	OK	NO	NO

* Always set the crown in the normal position

Water resistance

- To prevent water coming into contact with the internal mechanism of the watch, the crown should under no circumstances be pulled out while the watch is wet.
- If watches designed for sports or working in the water are exposed to salt water or significant amounts of sweat, they should be rinsed in fresh water and dried thoroughly.
- Exposure to water may affect the durability of some types of leather bands.
- Because the internal watch parts may hold some moisture, if the external temperature is lower than that inside the watch, the glass covering the watchface may fog up. If this fogging up is only temporary it causes no problem, however, if it persists over a long period of time you should discuss the matter with a salesperson at the shop where you purchased the watch or at a Citizen Service Centre.

Temperature

Avoid exposing the watch to direct sunlight or leaving it in extremely hot or cold locations for a long period of time.

- This will cause malfunctioning and shorten the life of a battery.
- This may cause your watch to gain or lose time and affect its other functions.

Shock

- This watch will withstand the bumps and jars normally incurred in daily use and while playing such non-contact sports as golf, etc.
- Dropping the watch on the floor or otherwise imparting severe shock to it may cause malfunctioning or damage.

Magnetic Fields

This watch is antimagnetic up to 60 gauss and not affected by the magnetic fields produced by ordinary household electric appliances. If used in the immediate vicinity of strong magnetism, however, the watch's functions may temporarily be affected.

Static Electricity

The integrated circuits used in the watch are sensitive to static electricity. If exposed to intense static electricity, the watch's display may lose its accuracy.

Chemicals and Gases

Avoid wearing the watch in the presence of strong chemicals and gases. If the watch comes in contact with such solvents as thinner and benzene or products containing materials such as gasoline, polish, detergent or adhesive, its components may discolor, dissolve or crack. Be especially careful to avoid chemicals. The watchcase or band may discolor if they come in contact with mercury from a broken thermometer or other equipment.

Keep Your Watch Clean

Wipe off soil and moisture from the glass with a soft, absorbent cloth. If you wear the watch when the backside of the case and watchband is soiled they may cause a skin rash as they come in direct contact with your skin. Keep your watch clean also to avoid staining your cuffs. How to clean the watchband:

- Metal band: Wash soiled parts with a tooth brush in mild, soapy water.
- Plastic and Rubber band: Wash in water. Do not use solvent.
- Leather band: Rub lightly on the front side with a soft, dry cloth. Use a cloth moisturised with alcohol to clean the underside.

Periodic Inspection

Getting your watch checked once every year or two is recommended to ensure long use and trouble-free operation.

Be sure to keep the batteries out of reach of infants and small children. Should accidental ingestion occur, consult a doctor at once.

- Refer to the diagram on "water resistance".

L. Specifications

1. Model: Analog quartz watch with altimeter

2. Accuracy of time: ± 20 seconds/month (5°C to 35°C/41°F to 94°F)

3. Quartz frequency: 32,768 Hz

4. Accuracy of altimetry: $\pm(5\% \pm 10\text{m}$ of the value display)
10°C to 40°C/50°F to 104°F
When adjusted the
altitude compensation.

5. Operating temperature range: -20°C to 55°C/36°F to 121°F

6) Additional functions:

- Calendar: (date)
- Altimetry function: -300m to 5,000m (in 10m gradation)
- Normal altimetry measurements: every 5 seconds (for 30 minutes)
- Altitude correction function: Compensation can be made within $\pm 300\text{m}$
- Chronograph function:
Maximum measured display: 99 minutes 59 seconds
Measurements of less than 1 minute are in 1/20 (0.05) second gradation;
Measurements of more than 1 minute are in one second increment
- Battery-low warning function

7. Battery life: Approx. 2 years

Operating conditions: When using the continuous altimetry function for
30 minutes and the chronograph for 100 minutes per day

8. Battery number: 280-44 (SR 927W)